

**CARACTERÍSTICAS TÉCNICAS / TECHNICAL FEATURES**

4.5006.000

Enrollador Universal p/Pasacables ANGUILA (vacío) /



Material	Capacidad Max. / Max. Capacity (m.)
Fibra Ø3	45
Nylon Ø4	45
Cordón Ø4	35
Trenzada Triple Ø4.5	35
Trenzada Mono Ø4.5	35

Revisión / Review : 28/01/21



**CARACTERÍSTICAS TÉCNICAS / TECHNICAL FEATURES**

4.5006.000

Enrollador Universal p/Pasacables ANGUILA (vacío) /

**Dimensiones / Dimensions**

Peso / Weight	0,94 Kg.
Eje / Axle	Mecanizado / Machined

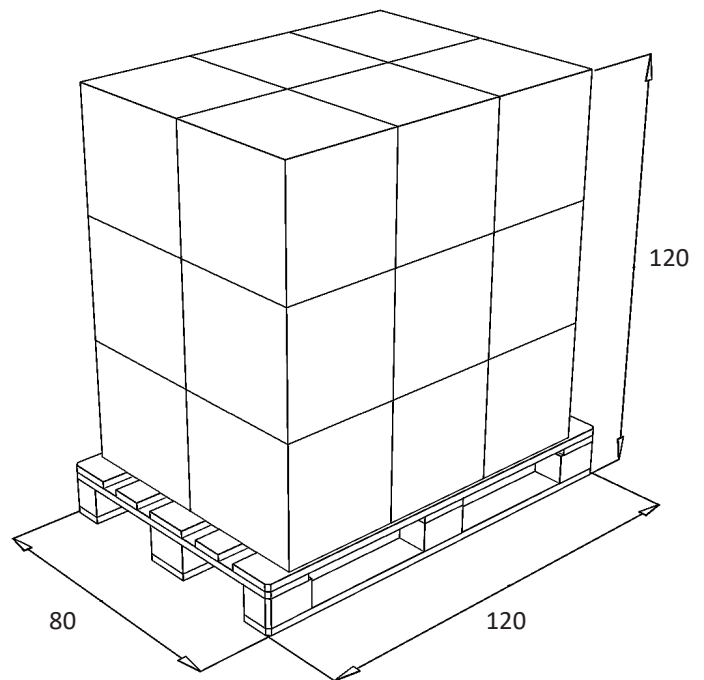
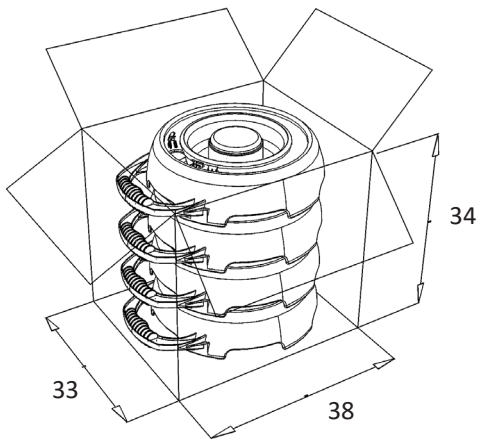
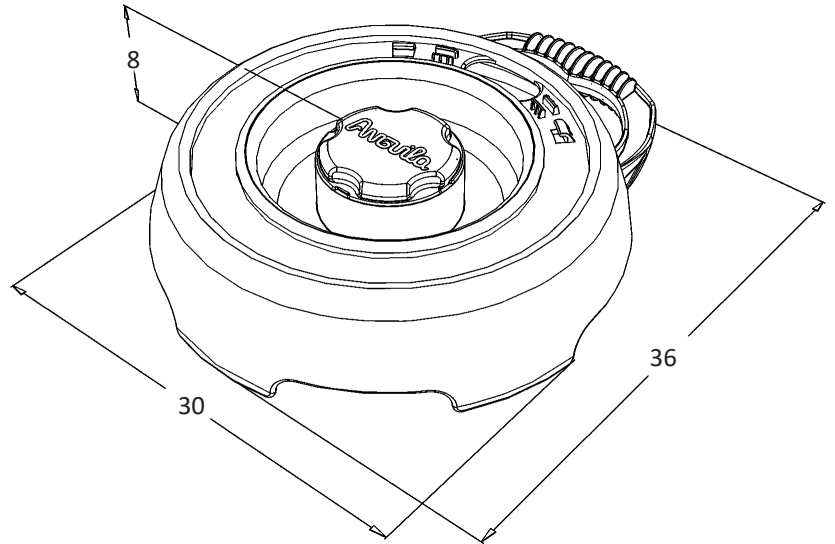

72 units  
PALLET

cotas en cm. / dimensions in cm

Revisión / Review : 28/01/21